

EZRUN USER MANUAL

Sensored Brushless Motor
EZRUN 70125SD

20211230



Thank you for purchasing this HOBBYWING product! The power of brushless power system is powerful. Any improper use may cause personal injury and damage to the product and related devices. We strongly recommend reading through this user manual before use and strictly abide by the specified operating procedures. We shall not be liable for any liability arising from the use of this product, including but not limited to reimbursement for incidental or indirect losses. Meanwhile, we do not assume any responsibility caused by unauthorized modification of the product. We have the right to change the product design, appearance, performance and use requirements without notice.

01 Warnings



- Please carefully check power devices and manual of car frame to ensure the power pairing is reasonable. Avoid wrong pairing to overload and damage the motor.
- Always wire up all the parts of the equipment carefully. If any of the connections come loose as a result of vibration, your model RC may lose control.
- Never apply full throttle if the pinion is not installed. Due to the extremely high RPMs without load, the motor may get damaged.
- Never allow the motor case to get 100 degrees Celsius (212 degrees Fahrenheit) because the magnets maybe demagnetized by high temperature.

02 Features

- Chip built in the motor, when matched with Hobbywing EZRUN MAX4 esc, it not only has perfect compatibility, the ESC can automatically identify the motor and build a pure/full sensor mode power system, providing better manipulating performance and more delicate manipulating feel.
- The rotor adopts four strong magnetic and high temperature resistant sintered Nd-Fe-B magnets, widens the magnetic tile, provides super torque, and makes the motor have strong explosive force and stable output power.
- The independent high-precision encoder always outputs pure rotor position signal, which effectively avoids the interference of sensor signal and makes the motor work stably in sensor state.
- High output efficiency, effectively reduce the motor temperature and output more power under the same load.
- CNC machined aluminum housing, high purity copper windings, advanced rotor structure, 0.2mm silicon steel laminations, high-quality stainless steel output shaft, high-precision bearing for high durability and smoothness.
- The innovative new sensor interface and rubber cover bearing have better waterproof and dustproof effect than the traditional sensor motor.

03 Specifications

Model	EZRUN 70125SD
PN	30402850
KV Value	560KV
Lipo Cells	8-12S Lipo
Resistance	0.0050Ω
No-load current	3.6A
Outer Diameter/Length	70mm (2.760in) / 125mm (4.921in)
Shaft diameter/Exposed shaft length	8mm (0.315in) / 30mm (1.181in)
Bearing size(mm)	D22*D8*T7
Pole	4
Weight	1995g
Application	1/5th Heavy-duty Off-road, Truck.

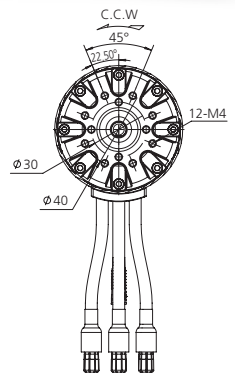
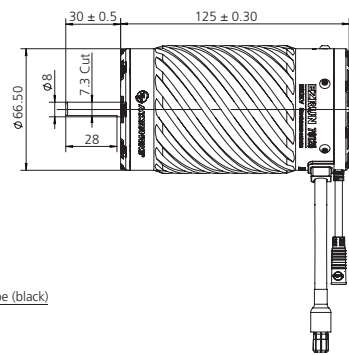
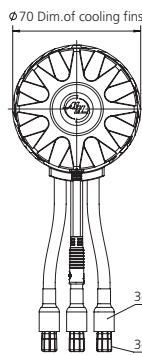

3-Heat shrink tube (black)
3-Ø8.0 GBC

04 Installation & Connection

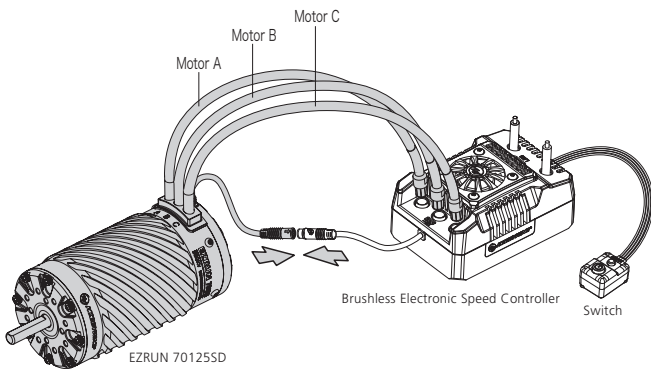

1. Install the motor

M4 mounting screws are needed there, and the mounting holes are 7mm in depth, before installing the motor on the vehicle, please carefully confirm whether the specification of the screws is appropriate according to the thickness of the motor mounting plate to avoid damage to the motor due to too long screws.

2. How to Connect the Motor to an ESC

- When connecting the motor and esc, please pay attention to the marked three-phase position of A, B and C to ensure that the three wires of the motor and esc are connected correspondingly. Otherwise, it cannot run normally and even damage the esc and motor.

That is: Wire A of the esc matches wire A of the motor, wire B of the esc matches wire B of the motor, wire C of the esc matches wire C of the motor.

- When the sensor wire of the motor is connected with the sensor wire of the esc, it shall be connected correspondingly according to the arrow mark on the sensor interface.

3. Inspection

Before power on the esc, please check the reliability of the motor installation and the correctness of all connections.

05 Gearing

Reasonable selection of gear ratio is very important. Improper gear ratio may bring you great loss. You can select the gear ratio according to the following points!

1. The running temperature of the motor

The motor temperature should be lower than 100 degrees Celsius (212 degrees Fahrenheit) in operation. Because high temperature may cause the magnets to get demagnetized, the coil to get melt and short circuited, and the ESC to get damaged. A suitable gearing ratio can effectively prevent the motor from overheating.

2. The principle of selecting gear ratio

To avoid the possible damage to ESC and motor caused by the overheat, please start with a small pinion/a big FDR and check the motor temperature regularly. If the motor and ESC temperature always stay at a low level during the running, you can change a big pinion/a low FDR and also check the motor temperature regularly to ensure that the new FDR is suitable for your vehicle, local weather and track condition. (Note: For the safety of electric devices, please check the ESC and motor temperature regularly.)

06 Assembly and Disassembly

In order to make the motor have longer service life and higher efficiency, we suggest to regularly check the bearing and clean the dirt in the motor. The specific time depends on the frequency of using the motor and the site conditions. When installing, please follow the steps in the following assembly drawing; when disassembling, follow the reverse steps.

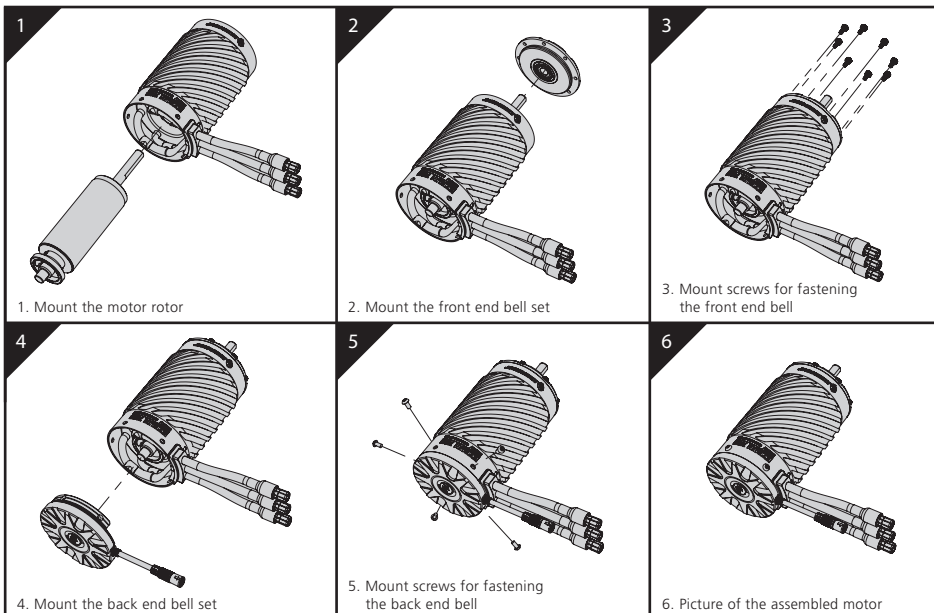

Parts List

